

Tunneling and Mining Applications of Fuelcell Vehicles

Arnold R. Miller, PhD
Fuelcell Propulsion Institute
Denver, CO
USA

Abstract

Underground vehicle applications — tunneling and mining — may be the first fuelcell-vehicle markets that succeed solely on economic merit. Providing traction power in these enclosed, highly regulated workplaces is a difficult challenge, and the inadequacies of conventional power are the basis of economic stress in the industries. Clean, safe, and productive fuelcell vehicles, while higher in capital cost, offer cost offsets that can make them the first commercially successful products. The Locomotive Project of the Fuelcell Propulsion Institute is developing and testing the world's first fuelcell-powered underground vehicle, a mine locomotive. The 25-month project involves more than 20 international partners, including mining companies, mine vehicle companies, mine regulators, organized labor, and national laboratories, and is internationally funded by two governments and the mining industry.

Introduction

Tunneling and mining offer the most immediate markets for successful fuelcell vehicle commercialization. The enclosed, underground operating environment exacerbates problems of vehicle emissions and noise. Despite high capital cost of the fuelcell, powerful cost offsets arising from solving these problems will make the fuelcell vehicle cost-competitive several years before surface applications (1, 2). These offsets allow the fuelcell vehicle to compete strictly on economic merit.

The mining industry faces economic losses resulting from the health and safety deficiencies of conventional underground traction power. Because workers are constrained to an underground workplace, mining is one of the most regulated industries. Conventional power technologies — tethered (including trolley), diesel, and battery — are not simultaneously clean, safe, and productive. For instance, tethered vehicles are power-dense and clean, but the tether is unsafe

and interferes with mobility and productivity. Diesel vehicles, nearly as power-dense, are more mobile and theoretically more productive, but government emissions regulations hamstringing actual productivity. Emissions and noise regulations (3) in the process of implementation will further increase vehicle capital and operating costs and lower mine productivity. Because the market price of metals and coal is low, the problem of underground power production places the industry in economic stress — downward forces on price and upward forces on costs.

Tunneling is even more hampered by inadequate traction power. A tunnel under development is a tube, perhaps 10 km long, closed at one end. Because ventilation is poor, operations may use staged vehicles: battery locomotives working near the face that hand off a train to diesel locomotives operating in better ventilation near the tunnel entrance. Multiple battery locomotives may be required — whereas one is sufficient for power, the others transport batteries. The potential economic value of solving the problem of traction power in tunneling exceeds that of mining.

Fuelcells offer a solution — and underground vehicles offer the opportunity that they will be the first commercially successful products. A fuelcell type well-suited to underground applications is the “hydride fuelcell” — the coupling of a fuelcell system with metal-hydride onboard energy storage. Benefits of fuelcells include zero emissions, low noise, high power density, low temperature/pressure operation, and long life. The PEM (Proton Exchange Membrane) fuelcell type, coupled with hydride storage, provides additional benefits critical to heavy-duty, underground applications: safety, compactness, simplicity, and ruggedness. Although hydride storage is heavy, weight is of no consequence in counter-balanced vehicles (e.g., loaders) or steel-wheeled vehicles (locomotives).

ECONOMIC ANALYSIS

Analyses by the Fuelcell Propulsion Institute show that hydride fuelcells will provide improved health and safety, enhanced performance, and reduced mine operating costs. We project that these cost offsets will make fuelcell vehicles cost-competitive at least three years earlier than projected for surface vehicle applications (1). The cost analysis addresses rubber-tired vehicles in coal mining, but similar results are expected for vehicles in hardrock metal mining and tunneling.

Current purchase costs are high for both fuelcells and metal hydrides because they are largely hand-built, manufacturing volume is low, manufacturing experience is limited, and development costs must be recovered. Labor is the largest component of manufacturing costs. The analysis focuses on replacement of the diesel vehicle because its productivity is the benchmark that the fuelcell vehicle must equal or exceed.

Application of diesel-powered equipment in coal mines is a difficult technical challenge. Because the vehicle operates in a potentially explosive environment, regulations require that no surface temperature exceed 150 C (302 F). This necessitates water-jacketed exhaust manifolds and water-scrubbed exhaust. Frequent emissions tests and system complexity lower vehicle availability and increase capital cost. Complete diesel systems for coal mining cost more than \$500/kW, far above the cost for surface applications.

The diesel engine is not inherently well-suited to underground operation. Constituents of diesel exhaust are known to be carcinogenic, and underground diesel operations require extensive ventilation. Noise is excessive. Proposed regulations require filtration of the exhaust to eliminate 95% of particulate matter. A consequence of compensating for the diesel's inherently poor health and safety characteristics is that complexity and cost will continue to rise and availability will fall. Hydride fuelcell systems obviate the complexity of underground diesel engines.

This study estimates the year when the hydride fuelcell vehicle is cost-competitive with the diesel version of three coal vehicles. It compares both recurring and capital costs of diesels with projections for hydride fuelcells. Recurring costs include (a) fuel, (b) tires, (c) driver and maintenance labor, (d) labor to assure conformance to diesel regulations, e.g., exhaust-gas sampling lost time, (e) consumable parts such as filters, (f) drivetrain maintenance due to breakdown and rebuild, and (g) engine control system (safety system) breakdown and rebuild costs. Capital cost projections were obtained via a survey of the fuelcell and metal-hydride industries and from the known cost of diesel vehicles. Projected capital costs assume production volumes that have substantial components other than mine vehicles. Capital costs include financing costs. Although diesel costs, both recurring and capital, will rise over the same time period, we conservatively assume a constant diesel cost. Since fuelcell costs are expected to fall, the study's objective is to determine at what time the falling fuelcell vehicle costs cross the constant diesel costs.

Although the fuelcell production vehicle will probably be more productive than a diesel vehicle — because of higher allowed vehicle density, higher availability, and substantially higher performance — and may lower non-vehicle subsidiary mine operating costs — e.g., ventilation costs — the scope of the study was limited to costs directly attributable to operation and purchase of the vehicle.

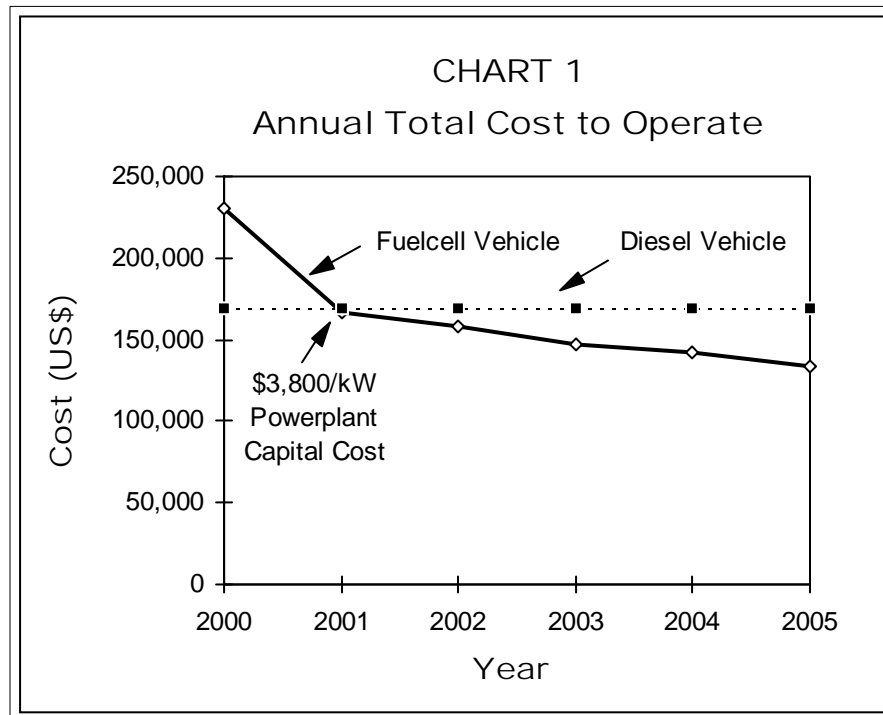

Chart 1 shows the trends for annual total costs for a typical coal vehicle (a scoop). When viewed in terms of the sum of annualized capital costs and annual recurring costs, the fuelcell vehicle is cost-competitive even while the capital cost of its hydride fuelcell powerplant is quite high. We predict that when the powerplant capital cost is as high as \$3,800/kW, compared to about \$500/kW for the diesel counterpart, it will nonetheless be cost-competitive. This follows because there are important cost components besides the purchase cost of an industrial vehicle, and these are lower for the fuelcell vehicle: Diesels are expensive to maintain and operate because they are inherently ill-suited to operate underground. It is primarily the reduction in recurring costs in the underground application that make the fuelcell vehicle cost-competitive so soon.

Accordingly, we believe the rate-limiting factors to commercialization are not capital cost but government regulations, acceptance by organized labor, and ramp-up time for product development.

Locomotive Project

During the past four years, the Fuelcell Propulsion Institute, an international technical and educational consortium¹, has proposed and analyzed hydride fuel-cells as a solution to the growing problem of providing underground traction power. The Institute, comprised of technology developers, manufacturers, and end-users, is structured as a nonprofit membership organization. Its mission is to spearhead industry-specific transitions to fuelcell propulsion by bringing together an industry's major stakeholders, applying their in-depth knowledge, developing the technology, and educating the public.

The principal business of the Institute is the development of fuelcell vehicles for applications with high commercialization potential. The Fuelcell Propulsion Institute itself, a nonprofit corporation, has no commercial objectives and acts as a facilitator for the ultimate benefit of the public-at-large.

Under the guidance of its primary customer, the mining industry, the Institute's 25-month Locomotive Project (4) involves all major players in North American mining — more than 20 international partners, including mining companies, mine vehicle companies, mine regulators, organized labor, and national laboratories. The world's first fuelcell locomotive is scheduled for completion by 9 October 2000, the starting date for its display at MINExpo INTERNATIONAL 2000SM in Las Vegas, NV, USA. MINExpo[®] is the largest event of its kind in the world and features the newest equipment and technology available in the mining and tunneling industries. It occurs only every four years.

POWER

Because of the well-behaved characteristics of steel wheels on steel rails, we have established the power requirements of the vehicle analytically (2, 5). The track system of underground metal mines is almost universally on a 0.5% grade,

¹Atlas Copco Wagner Inc, Barrick Gold Corporation, Bituminous Coal Operators' Association (BCOA), Canada Centre for Mineral and Energy Technology (CANMET), Cast Resource Equipment Ltd, H Power Corporation, Inco Limited, Long-Airdox Company, McNally International Inc, Mining Technologies International Inc, National Mining Association, National Renewable Energy Laboratory, National Rural Electric Cooperative Association (NRECA), Noranda Inc, Pennsylvania State University, Placer Dome Inc, RA Warren Equipment Ltd, Sandia National Laboratories/California, Sandia National Laboratories/New Mexico, Sandvik Tamrock Corporation, Société de Recherche et Développement Minier (SOREDEM), South Dakota State University, Stuart Energy Systems, U.S. Department of Agriculture/ARS (in process), Virginia Tech, Westinghouse Safety Management Solutions, Inc, Westinghouse Savannah River Company

with the mine face being uphill of the dump point: Ore is loaded into the cars at the top of the grade, they are pulled downhill, dumped, and returned uphill empty. This operational method provides two benefits: (a) The system exploits gravity to assist the removal of ore from the mine and (b) water drains out of the mine rather than into it.

The maximum power in the duty cycle of the locomotive is the power developed during the initial stall condition of startup (acceleration from rest) for the fully loaded train on a 0.5% grade. While a benefit of rail vehicles is the low coefficient of friction between steel wheels and steel rails, startup torque is also limited by wheel slippage during acceleration. The vehicle employs a programmable, smart motor controller that limits startup torque to a value below that causing wheel slippage. Because stall current is limited by the controller, the locomotive maximum power requirement is in fact determined by the motor controller rather than limited by the power source. We estimate 6 kW as the average power over the duty cycle.

The locomotive manufacturer has developed equations and tables of empirical parameters (5) that allow computation of the maximum allowed tractive effort at startup that is simultaneously consistent with wheel adhesion. The calculations below first compute this maximum allowable tractive effort (TE_{max}). From TE_{max} , we derive the traction-motor shaft torque, and from the torque-versus-current curve of the traction motor, the corresponding motor current. By estimating the corresponding battery voltage, we determine the maximum power P_{max} that the fully loaded locomotive can develop — at stall on a 0.5% grade — and avoid wheel slippage. P_{max} is the required maximum power of the fuelcell.

Definitions and values of parameters used in the analysis are collected in the accompanying table.

Total motion resistance RT to the train is a function of four resisting forces: rolling resistance R_r , grade resistance G_r , inertia A_r , and resistance due to curvature of the tracks C_r . Thus,

$$RT = R_r + G_r + A_r + C_r. \quad (1)$$

Substituting the values from the table gives

$$\begin{aligned} RT &= 25 \text{ lb/ton} + 10 \text{ lb/ton} + 5 \text{ lb/ton} + 0 \text{ lb/ton} \\ &= 40 \text{ lb/ton} \end{aligned} \quad (2)$$

DEFINED AND CALCULATED PARAMETERS		
Parameter	Value	
L	Locomotive weight	4.0 ton (U.S.)
Rr	Rolling resistance of train (lb/ton)	25 lb/ton for steel wheels at startup
Gr	Grade resistance — gravity (lbs/ton)	10 lb/ton for 0.5% grade
Ar	Acceleration resistance or inertia (lb/ton)	5 lb/ton for standard acceleration of 0.05 m/s ²
Cr	Curvature resistance of track (lb/ton)	Assume zero
Ad	Wheel adhesion (lb/ton)	400 lb/ton for steel wheels at startup
Tw	locomotive gear-reduction ratio	17 (i.e., 17:1)
Wr	Wheel radius (m)	0.23 m
TL	Trailing load weight (ton)	Calculate
RT	Total motion resistance (lb/ton)	Calculate
TE	Tractive effort (lb, N)	Calculate
Ts	Torque at traction motor shaft (Nm)	Calculate
P	Power (kW)	Calculate

Define the trailing load TL as the weight of the loaded train cars. When the locomotive wheel adhesion force (friction) is in balance with the total motion resistance (RT) force, we have the equilibrium described by equation (3):

$$L(Ad - RT) = TL \times RT. \quad (3)$$

Solving this for TL, we find the acceptable trailing load for our conditions:

$$\begin{aligned} TL &= L(Ad - RT)/RT \\ &= 4.0 \text{ ton} (400 \text{ lb/ton} - 40 \text{ lb/ton})/40 \text{ lb/ton} \\ &= 36 \text{ ton.} \end{aligned} \quad (4)$$

The maximum startup tractive effort, without wheel slip, is the product of the total motion resistance force (lb/ton) and the total acceptable weight of the train (ton):

$$\begin{aligned} TE_{\max} &= RT(L + TL) \\ &= 40 \text{ lb/ton} (4.0 \text{ ton} + 36 \text{ ton}) \end{aligned} \quad (5)$$

$$= 1600 \text{ lb}$$

$$= 7100 \text{ N.}$$

Working backward, the traction-motor shaft torque T_s necessary to provide this tractive effort is given by

$$T_s = TE_{\max} \times W_r/T_w \quad (6)$$

$$= (7100 \text{ N} \times 0.23 \text{ m})/17$$

$$= 96 \text{ Nm.}$$

From the traction-motor performance curves, the current required to produce 96 Nm of torque is determined. By estimating the traction battery's corresponding voltage, the maximum power P_{\max} consistent with wheel adhesion is computed as 13.3 kW net at startup stall (2, 5).

Fuelcell Locomotive

The base vehicle for the project is a commercial four-ton battery locomotive manufactured by consortium member RA Warren Equipment. The vehicle employs a 52-cell lead-acid battery (104 V nominal), series traction motor with interpoles, smart motor controller, double-enveloping gear drive, hydraulically assisted disc brakes, and unitized body/chassis. An illustration of the derived fuel-cell locomotive is shown below; the front of the vehicle is to the right.

The locomotive's powerplant uses a proton-exchange membrane (PEM) fuelcell. No traction battery is employed, and the vehicle is thus a pure fuelcell vehicle.

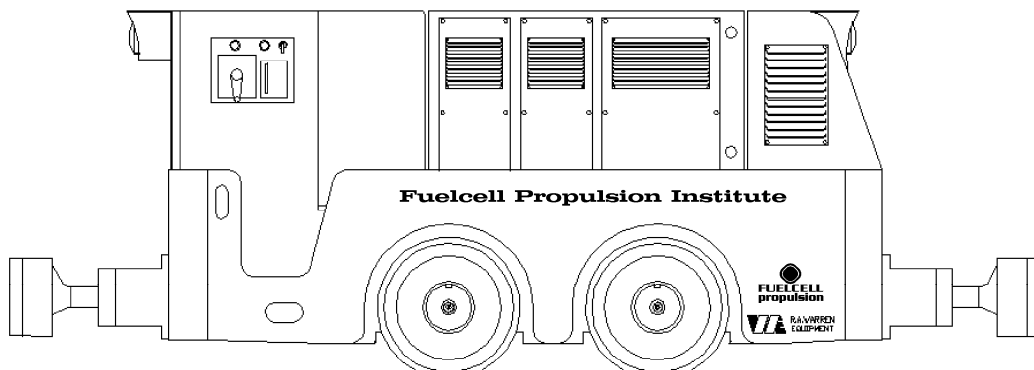

The stacks, undergoing fabrication, are a rugged industrial design, using metal bipolar plates, that has been tested under extreme conditions by the Ecole des Mines in France. Two stacks in electrical series give 104 V and 135 A at the continuous rated power of 14 kW gross. Each stack, with integral humidifier, weighs 30 kg and has a volume of 25 L. The air cathode operates at 0.5 bar above ambient pressure. Because the overload capacity of the fuelcell is at least as great as the parasitic load of system ancillaries, the 14 kW gross-power stacks can provide at least the 13.3 kW net required during the transient overload of startup stall.

The state-of-the-art hydride storage system, under development by consortium member Sandia/CA, will store 3 kg of hydrogen, sufficient for eight hours of locomotive operation at the 6 kW average power of its duty cycle. The bed uses approximately 200 kg of C-15 alloy (an alloy of manganese, titanium, zirconium, iron, and other constituents from GfE) stored in 12 cylinders, each having an outside diameter of 12.7 cm, inside diameter of 11.4 cm, and height of about 65 cm. Weight of each loaded cylinder is 25 kg, and outer volume of the group is 100 L. The C-15 alloy was chosen for its room-temperature performance characteristics, with pressure ranging from 1 to 10 bars over the temperature range 20 - 60 C. Bed capacity is 1.8 weight per cent. System pressure is limited by a relief valve to 10 bar and system pressure capability will be tested at 40 bar.

Hydride system design allows for rapid change-out (swapping) of a discharged bed with a freshly charged unit. The radiator is designed to maintain bed temperature below 50 C and allow recharging, either onboard or offboard, in 30 minutes. Recharging will utilize gaseous hydrogen at seven bars.

The proprietary powerplant is being developed for the consortium by member Sandia/CA. The complete system — stacks, fuelcell balance-of-plant, hydride storage system, and all system controls — packaged in a stand-alone subframe is illustrated below. A heat exchanger links two isolated thermal systems: (a) the hydride-bed heating/cooling loop and (b) stack cooling loop. The bed loop uses a circulating anti-freeze medium, whereas the stack loop uses demineralized water. Stack cooling water also passes through a forced-air excess-heat radiator. Coolant pumps and the stack air pump are powered at system startup by an auxiliary battery recharged by the stacks.

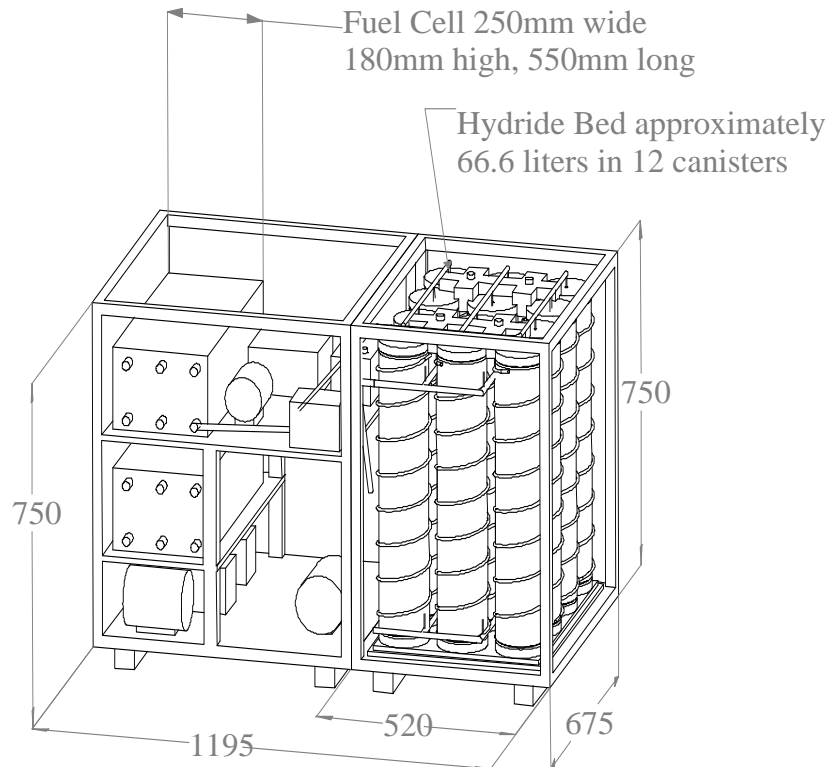

The fuelcell locomotive will match or exceed the battery vehicle in performance while having greater availability. Its calculated power and tractive effort are equal or greater. Vehicle operating time on a full hydride charge is eight hours, versus a practical battery operating time of six hours. It can be refueled in 30 minutes rather than eight hours. The complete hydride fuelcell powerplant (see illustration) is one-third the weight of the battery, and ballast must be added to bring vehicle weight to the four tons assumed in the power analysis. The powerplant has half the water-displacement volume of the battery. By relaxing power density, available chassis volume should accommodate two additional hydride beds and allow continuous locomotive operation for 24 hours. Comparisons of the battery and hydride fuelcell power sources are given in the accompanying table.

Although low-temperature hydride storage is often considered too heavy for light-duty vehicles, our entire powerplant (fuelcell plus storage) is one-third the weight of the corresponding lead-acid battery. The powerplant will be somewhat heavier than a diesel engine, including fuel tank, but weight is not an issue for many underground vehicles, e.g., loaders, lift-trucks, and locomotives. Far more important is safety and minimum volume: workers are highly confined and all available

Comparison of Battery and Fuelcell Powerplant		
Parameter	Battery	Powerplant
Power, continuous	7.1 kW (net)	14 kW (gross)
Current, continuous	71 A	135 A
Voltage at continuous rating	101 V	104 V
Weight of components	1650 kg	< 550 kg
Volume of components	520 L	< 250 L
Energy capacity, electrical	43 kWh	48 kWh
Operating time	6 h (available)	8 h
Recharge time	8 h	½ h (expected)

space had to be dug out of rock. Thus, the combination of metal-hydride storage and PEM fuelcells is an ideal solution for underground traction power.

Vehicle Evaluation

Under the direction of the Mine Safety and Health Administration (MSHA), the agency within the US Department of Labor responsible for safeguarding the safety and health of the mining workforce, the vehicle will be tested aboveground for safety. Objective is to validate the safety of various features, listed below, before the vehicle is taken into operating mines for the productivity tests:

- Integrity of fittings, piping, and fuelcell with respect to gaseous hydrogen
- Guarding of components within the machine frame
- Routing of piping and wiring between components
- Hydride-bed refueling by gaseous transfer
- Refueling by bed change-out (swapping)
- Vulnerability of refueling to mud, water, air, and other contaminants
- Effects of shock and vibration on system integrity
- Training requirements of mining personnel
- Acceptance of hydrogen storage and refueling by workers and regulators.

The vehicle will also be tested for performance at the aboveground site. Objective is to demonstrate that its performance is adequate to not disrupt mine operations during underground evaluation:

- Tractive effort

- Grade climbing
- Tram speed
- Operating duration on a full charge
- Refueling time
- Shock and vibration resistance
- Overload capacity
- Ergonomics and human control characteristics.

Under the direction of the Canada Centre for Mineral and Energy Technology (CANMET), a Canadian national laboratory and consortium member, the locomotive will be evaluated while working in four underground metal mines. Besides evaluating productivity in actual underground working conditions, the tests will lay the foundation for subsequent development of vehicles for coal mining. Specific field assessments include productivity, reliability, availability, practicality, and safety of the hydride fuelcell locomotive. It will be compared directly with battery versions of the vehicle.

Conclusions

Fuelcells coupled with metal-hydride storage, by solving the problem of underground traction power, offer cost offsets — higher productivity and lower operating costs — making them cost-competitive sooner than surface applications. Compared to the battery vehicle from which it is derived, the fuelcell locomotive has equivalent power and tractive effort, at least twice the volumetric energy density, and greater availability. By relaxing power density, chassis volume should accommodate two additional hydride beds, giving a vehicle that can operate continuously for 24 hours. Because weight is not an issue for many key production vehicles, safe and compact metal-hydride storage is an ideal storage solution for underground vehicle applications.

References

- (1) D. W. Gaibler and A. R. Miller, Cost model for fuelcell mine vehicles: conservative analysis of recurring and capital costs. Fuelcell Propulsion Institute, Denver, CO, USA, 7 December 1998.
- (2) A. R. Miller, Commercialization of fuelcell underground locomotives. Proceedings of the Intertech conference "Commercializing Fuel Cell Vehicles 2000," Berlin, Germany, 12-14 April 2000.
- (3) J. Wilson, MSHA speaks out: new standard to control occupational noise exposures. "Safety and Health," 1 April 2000, pp. 2-7.

- (4) A. R. Miller, H. A. Bursey, G. C. Story, M. C. Bétournay, and G. J. Thomas, Underground fuelcell locomotives and their applications. Proceedings of the conference "Fuel Cell 2000," Lucerne, Switzerland, 10-14 July 2000, in press.
- (5) A. R. Miller, H. A. Bursey, A. I. Attia, and W. D. Muir, Maximum power of the Fuelcell Propulsion Institute's mine locomotive. Fuelcell Propulsion Institute, Denver, CO, 2 August 1999.

Acknowledgments

The Locomotive Project is funded by the US Department of Energy, Office of Power Technologies, through Hydrogen Program cooperative agreement DE-FC36-99GO10458; Natural Resources Canada through CANMET/IERD contract 23440-991022; and Vehicle Investment Partners LLC, Denver, CO, USA. Funding for powerplant development is provided by direct funding of Sandia National Laboratories/CA by the DOE Hydrogen Program. The Fuelcell Propulsion Institute and its projects are managed and operated by TransConsortia LLC, Denver, CO, USA. Lead partners in the Locomotive Project are RA Warren Equipment, North Bay, ON, Canada (provision of the base locomotive and vehicle design); Nuvera Fuel Cells, Cambridge, MA, USA, and Milan, Italy (fabrication of stacks); Sandia National Laboratories, Livermore, CA, USA (powerplant development, including hydride storage); Atlas Copco Wagner, Portland, OR, USA (vehicle integration and aboveground evaluation site); MSHA, Arlington, VA, USA (safety evaluation); and CANMET, Ottawa, ON, Canada (underground productivity evaluation). RA Warren Equipment provided the locomotive illustration and Sandia/CA provided the powerplant illustration. I thank my co-authors of earlier papers (1, 4, 5) for their contributions to this summary.